

FISHER & PAYKEL

SPECIFICATION GUIDE

DOUBLE DISHDRAWER™ DISHWASHER



OVERVIEW

With a contemporary stainless steel finish, each drawer washes independently and fits a half load, so you can run one while you load the other.

MODELS

Double DishDrawer™ Dishwasher

Stainless Steel
DD24DAX9 N

SERIES & STYLE

Series 7
Contemporary Style

FEATURES

- ① DishDrawer™ Dishwashers are designed to match the Fisher & Paykel family of kitchen appliances
- ② Six wash programs to suit any load, from Delicate to Heavy
- ③ Quick, Sanitise and Extra Dry provide extra wash options
- ④ Use both drawers independently, with the ability to select different wash programs
- ⑤ American Disabilities Act (ADA) compliant, this Double DishDrawer™ sits at an accessible height

ACCESORIES

- ① Cutlery basket
- ② Kickstrip

FISHER & PAYKEL

SPECIFICATION GUIDE

DOUBLE DISHDRAWER™ DISHWASHER

SPECIFICATIONS

| | |
|------------|--|
| Model No. | DD24DAX9 N |
| Dimensions | H 32 5/16" - 34 5/8" (820mm - 880mm) x W 23 9/16" (599mm) x D 22 9/16" (573mm) |
| Weight | 51kg |
| Electrical | |
| Supply | 110-120V, 60Hz |
| Service | 8.7A |
| Receptacle | 3 prong grounding-type |
| Plumbing | |
| Supply | Supplied hose to suit 3/8" (9mm) male compression fitting |
| Pressure | Max. 1 MPa (145 psi), min. 0.03 MPa (4.3 psi) |

PLUMBING AND ELECTRICAL

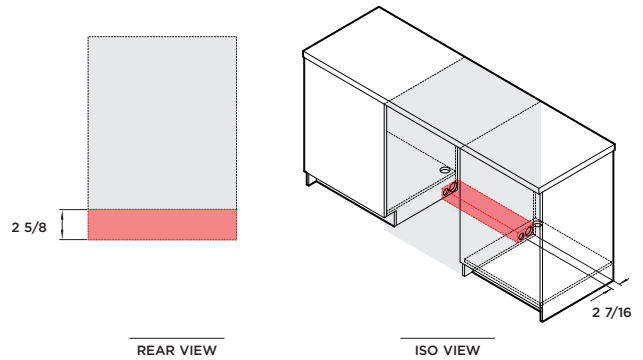

Service outlet at rear extends both sides, hoses and cords can be routed to either or both sides

PRODUCT DIMENSIONS

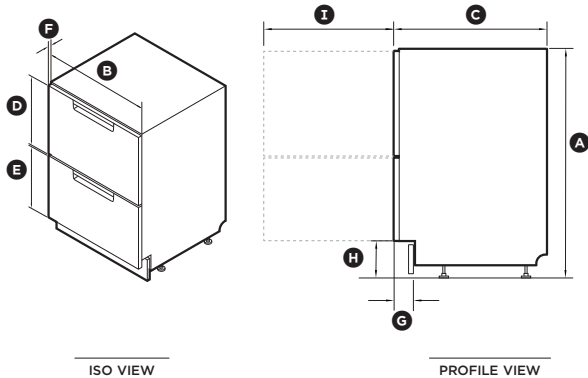

| | in | mm |
|--|------------------|-----------|
| Ⓐ Overall height* | 32 5/16 - 34 5/8 | 820 - 880 |
| Ⓑ Overall width | 23 9/16 | 599 |
| Ⓒ Overall depth | 22 9/16 | 573 |
| Ⓓ Height of upper front panel | 15 1/2 | 393 |
| Ⓔ Height of lower front panel | 14 | 356 |
| Ⓕ Depth of front panels | 13/16 | 20 |
| Ⓖ Depth of toe kick recess | 1 1/2 - 4 | 38 - 102 |
| Ⓗ Height from floor to front panel base* | 2 3/16 - 4 9/16 | 56 - 116 |
| Ⓘ Depth of open drawer | 21 9/16 | 547 |

*Depending on adjustment of levelling feet

CAVITY DIMENSIONS: STANDARD INSTALLATION

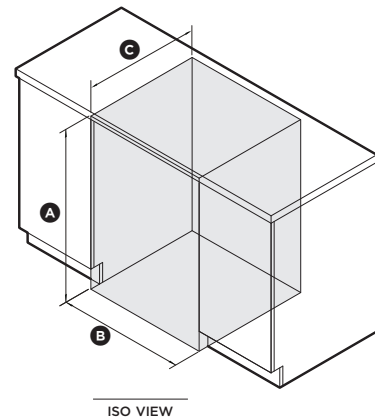

| | in | mm |
|-------------------|----------|-----------|
| Ⓐ Overall height* | 32 5/16 | 820 - 880 |
| Ⓑ Overall width | 23 5/8 | 599 |
| Ⓒ Overall depth** | 22 13/16 | 580 |

*Depending on adjustment of levelling feet

**Includes front panels